

DV-9/9s

9,000 LB Electric Winch

DV-9 PN 856329 12V | PN 856355 24V (with wire rope, roller fairlead, remote control)
DV-9s PN 859252 12V | PN 859262 24V (with synthetic rope, hawse fairlead, remote control)



DIMENSION mm/in :

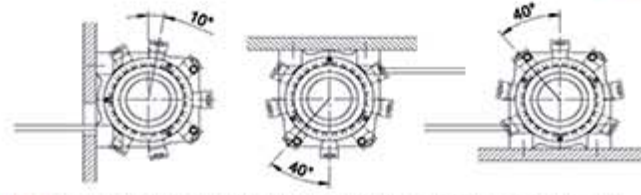
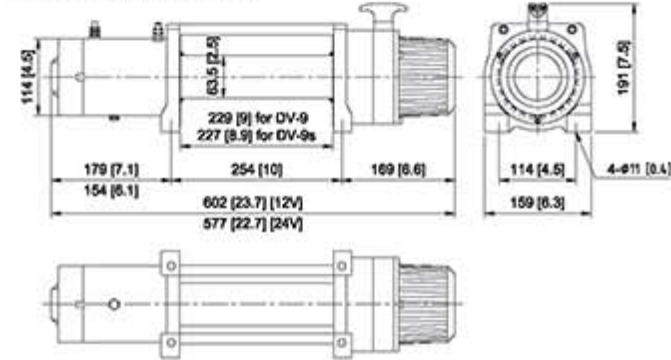

9 equally positioned pin holes ensure seamless clutch transmission and make it easily rotate by 40° increments. (DV-9i/9si/9/9s)

DV-9i/9si

9,000 LB Electric Winch

DV-9i PN 856360 12V | PN 856388 24V (with wire rope, roller fairlead, remote control)
DV-9si PN 859038 12V | PN 859055 24V (with synthetic rope, hawse fairlead, remote control)



SPECIFICATIONS :

Rated line pull : 4,082 kg (9,000 lb) single line
Motor : 3,430 w / 4.6 hp, 12V series wound w/thermal protection switch
1,940 w / 2.6 hp, 24V series wound w/thermal protection switch
Gear train & ratio : 3-stage planetary 156:1
Clutch (freespooling) : Rotating ring gear
Brake (outside the drum) : Automatic, full load CBS (Cone Brake Structure)
Winch construction : Aluminum die cast housings with steel drum
Drum size : DV-9/9i : 63.5 x 229 mm (2.5" x 9")
DV-9s/9si : 63.5 x 227 mm (2.5" x 8.9")
Control : Waterproof remote with thermometric indicator LED w/5 m (17') cord
Rope : DV-9/9i : Galvanized aircraft A7 x 19, 8.3 mm x 30.5 m (21/64" x 100')
DV-9s/9si : Synthetic rope, 10 mm x 30.5 m (3/8" x 100')
Recommended battery : 650 CCA minimum for winching
Battery lead : 1.8 m (6') 2 gauge battery lead
Mounting bolt pattern : 254 x 114 mm (10" x 4.5")
Winch weight (including rope) : DV-9 : 33 kg / 72.8 lb ; DV-9s : 27 kg / 59.5 lb
DV-9i : 37 kg / 81.6 lb ; DV-9si : 31 kg / 68.3 lb
Gross weight : DV-9 : 43 kg / 94.8 lb ; DV-9s : 33 kg / 72.8 lb
DV-9i : 44 kg / 97 lb ; DV-9si : 37 kg / 81.6 lb
Box dimension, (L x D x H) : 650 x 195 x 415 mm (25.6" x 7.7" x 16.3")

PERFORMANCE DATA :

Line Pull and Rope Capacity

| Layer of Rope | Pull by Layer, kg / lb | Total Rope on the Drum, m / ft | |
|-----------------|------------------------|--------------------------------|-------------|
| | | DV-9/9i | DV-9s/9si |
| 1 st | 4,082 / 9,000 | 6.1 / 20.0 | 5.5 / 18.1 |
| 2 nd | 3,316 / 7,310 | 13.6 / 44.7 | 12.5 / 41.0 |
| 3 rd | 2,792 / 6,154 | 22.6 / 74.0 | 20.9 / 68.6 |
| 4 th | 2,410 / 5,314 | 30.5 / 100 | 30.5 / 100 |

Line Speed and Amp. Draw (1st layer of rope on the drum)

| Line Pull kg / lb | Line Speed, mpm / fpm | | Amp. Draw, A | |
|-------------------|-----------------------|-------------|--------------|-----|
| | DV-9/9i | DV-9s/9si | 12V | 24V |
| No Load | 13 / 42.7 | 13.2 / 43.3 | 55 | 30 |
| 907 / 2,000 | 4.6 / 15.0 | 4.7 / 15.3 | 110 | 65 |
| 1,814 / 4,000 | 3.4 / 11.0 | 3.4 / 11.2 | 200 | 100 |
| 2,722 / 6,000 | 2.7 / 9.0 | 2.8 / 9.1 | 230 | 130 |
| 3,629 / 8,000 | 2.3 / 7.5 | 2.3 / 7.6 | 260 | 170 |
| 4,082 / 9,000 | 2.0 / 6.4 | 2.0 / 6.5 | 350 | 210 |

DIMENSION mm/in :

