

Technical data

Pump name

3LSF 32-200/5.5

Customer	Date 19-May-2020	Company
Contact	Item no.	Issued by
Phone	Project	Phone
E-mail	Project ID	E-mail

Requested data

1	Pump type	CENTRIFUGAL PUMPS	Fluid	Water, clean
2	Number of pumps / Reserve	1 / 0	Liquid temperature	K 293
3	Flow l/min	0	Kin. viscosity	mm ² /s 1
4	Head m	0	Vapour pressure	kPa 2.2
5	Geodetic head m	0	PH value	7
6	Inlet pressure (pin) kPa	10	Density	kg/m ³ 1000
7	Available system NPSH	0	Solids	Weight % 0
8	Ambient temperature	K 290		

Pump

9	Pump name	3LSF 32-200/5.5	Frequency	Hz 50
10	Design	CENTRIFUGAL PUMPS	Installation type	STANDARD
11	Manufacturer	EPE	Impeller Diameter	Max. mm 224
12	Speed 1/min	2900		Designed mm 224
13	No. of Stage	1		Min. mm 224
14	Connection Suction side	DIN 2532	Flow	Operating l/min
15	Connection Discharge side	DIN 2532		Max- l/min 300
16	Max Working Pressure kPa	1000		Min- l/min 100
17	Shut-off head kPa	690.24	Head	Operating m
18	Total weight kg	See the table of "Dimensions".		- (Qmax.) m 58.3
19	Shaft power kW			- (Qmin.) m 68.9
20			Max. Shaft Power at max. impeller	kW 5.47
21	Required pump NPSH m		Efficiency	%

Materials

22	Impeller	AISI 316L	
23	Casing	AISI 316L	
24	Shaft	AISI 316L	
25			
26			
27			

Motor

28	Manufacturer	without motor	Insulation class	
29	Type	without motor 3	Phases	3~
30	Specific design	without motor / 50 Hz / Pole pairs 1	Frame size	
31	Rated power kW	-	Weight	kg 0
32	Number of poles	2	Electric voltage	V 0
33	Speed 1/min	-	Electric current	A 0
34	Degree of protection	--		
35				

Remarks

Performance curve Pump name 3LSF 32-200/5.5

Customer	Date 19-May-2020	Company
Contact	Item no.	Issued by
Phone	Project	Phone
E-mail	Project ID	E-mail

Requested data

1	Flow	l/min	0
2	Head	m	0
3	Geodetic head	m	0

Pump

Operating Flow	l/min	Frequency	Hz	50
Operating Head	m	Number of poles	2	
Impeller Diameter	Designed mm	224	Speed	1/min

Test standard: ISO 9906:2012 - Grade3B

Water, clean [100%] ; 293K; 998.3kg/m³; 1mm²/s

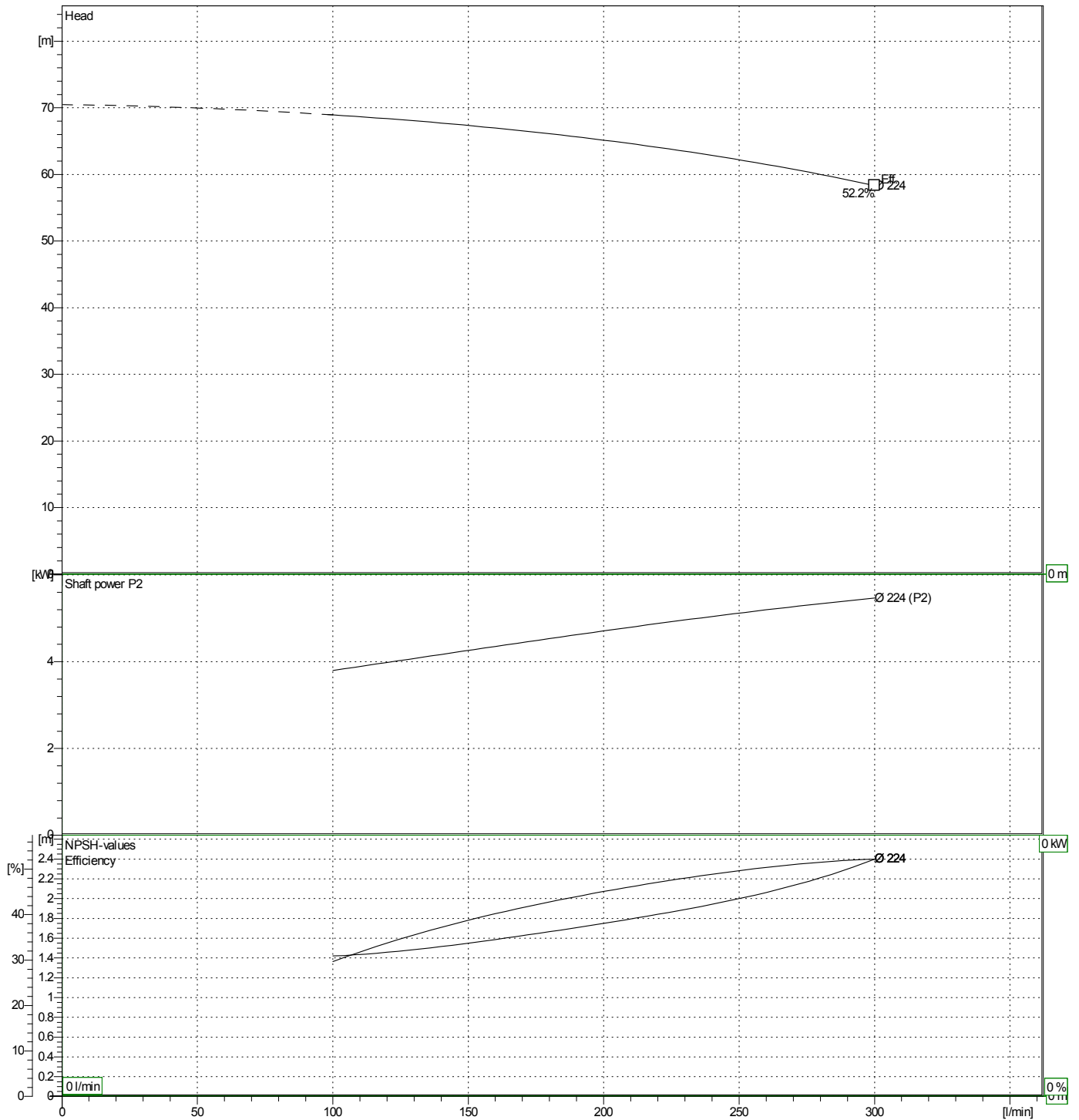

Dimensions

Pump name 3LSF 32-200/5.5

Customer	Date 19-May-2020	Company
Contact	Item no.	Issued by
Phone	Project	Phone
E-mail	Project ID	E-mail

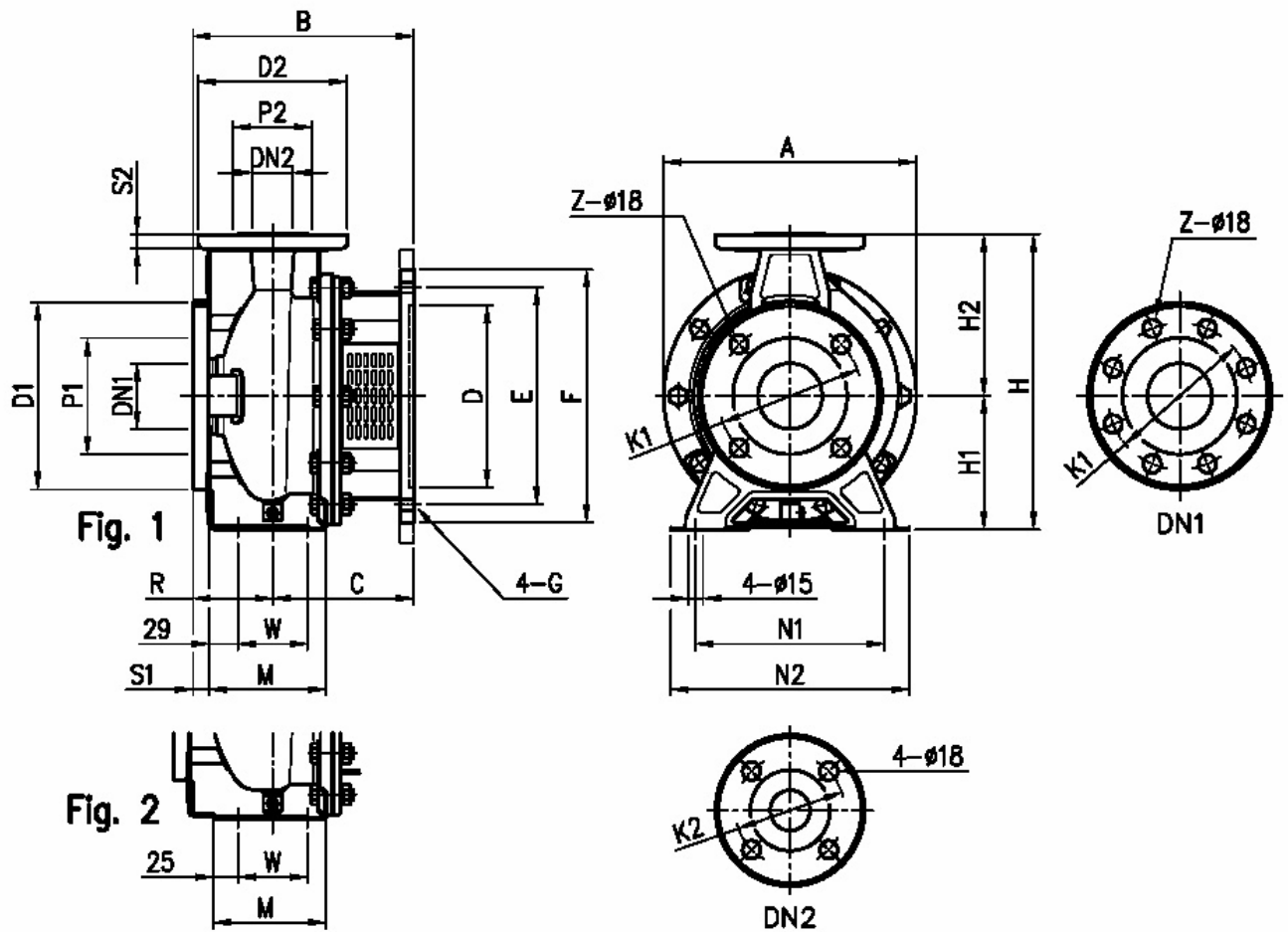

Dimensions in		mm					
1	A	296	F	300	Weight PUMP	28 kg	
2	B	245	Fig	1	Z	4	
3	C	165	G	M12			
4	D	230	H	340			
5	Dia D1	165	H1	160			
6	Dia D2	140	H2	180			
7	Dia DN1	50	M	119			
8	Dia DN2	32	N1	190			
9	Dia K1	125	N2	240			
10	Dia K2	100	R	80			
11	Dia P1	95	S1	16			
12	Dia P2	75	S2	14			
13	E	265	W	70			

(1/3) Construction

Pump name 3LSF 32-200/5.5

Customer	Date 19-May-2020	Company
Contact	Item no.	Issued by
Phone	Project	Phone
E-mail	Project ID	E-mail

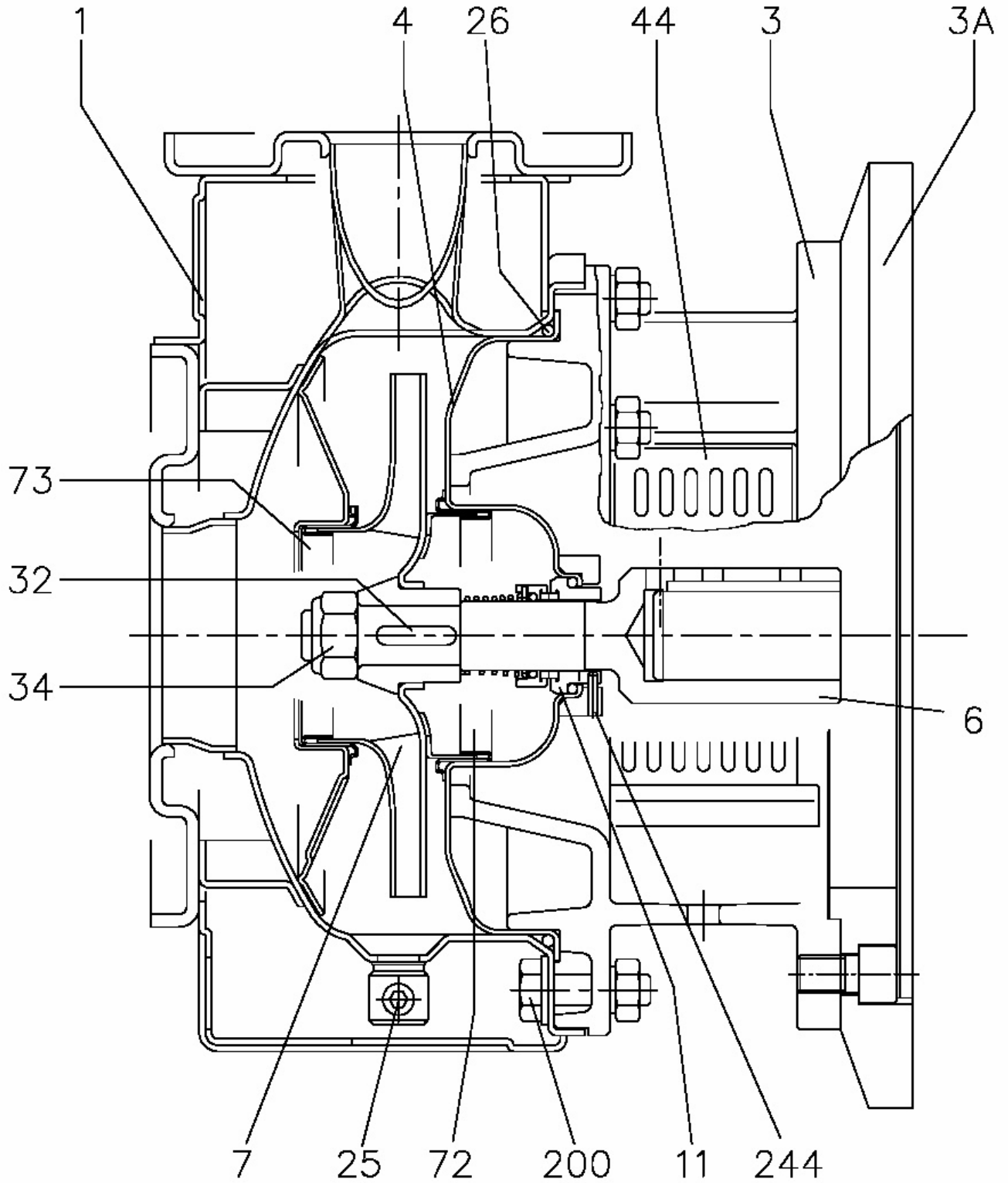

(2/3)**Construction**

Pump name 3LSF 32-200/5.5

Customer	Date 19-May-2020	Company
Contact	Item no.	Issued by
Phone	Project	Phone
E-mail	Project ID	E-mail

N°	PART NAME	MATERIAL		DIMENSIONS	STANDARD	Q.TY
		3SF	3LSF			
1	Casing	EN 1.4301 (AISI 304)	EN 1.4404 (AISI 316L)			1
3	Motor bracket	Cast iron EN-G JL-200-EN 1561				1
3A	Adapter ring [1]	Cast iron EN-G JL-200-EN 1561				1
4	Casing cover	EN 1.4301 (AISI 304)	EN 1.4404 (AISI 316L)			1
6	Coupling - Part in contact with liquid	EN 1.4301 (AISI 304)	EN 1.4404 (AISI 316L)			1
7	Impeller 32,40,50 65-125/160/200	EN 1.4301 (AISI 304)	EN 1.4404 (AISI 316L)			1
11	Mechanical seal [5]	Carbon/Ceramic/NBR	SiC/SiC/FPM			1
25	Draing plug	EN 1.4401 (AI SI 316) / PTFE		R 1/8" L=8	DIN 906	1
26	O ring 32-125, 40-125 32-160, 40-160, 50-125, 65-125 32-200, 40-200, 50-160, 50-200, 65-160, 65-200	NBR [6]	FPM	158.11x5.34	OR 6625	1
				183.52x5.34	OR 6720	
				227.96x5.34	OR 6895	
32	Key Up to 11 kW 15 kW and above	EN 1.4301 (AISI 304)	EN 1.4401 (AISI 316)	6x6x25 8 x7x 30	UNI 6604	1
34	Impeller nut Up to 11kW 50-200/15 15 kW and above	EN 1.4301 (AISI 304)	EN 1.4404 (AISI 316L)	M16x1.5 M18x1.5 M20x1.5	UNI 7474	1
44	Protection	EN 1.4301 (AISI 304)			EBARA DRAWING	1
72	Casing ring [2]	EN 1.4301 (AISI 304)	EN 1.4404 (AISI 316L)			1
73	Casing ring (not for 65 version)	EN 1.4301 (AISI 304)	EN 1.4404 (AISI 316L)			1
200	Screw 32-125, 40-125 40-160, 40-200, 50-125, 50-160, 50-200, 65-125, 65-160, 65-200	Stainless steel A2 70 class ISO 3506/ 1		M 8x30	UNI 5739	8
				M 10x35	UNI 5739	
244	Pin [4]	/	EN 1.4301 (AISI 304)	4x15		1

[1] Only for 65-125/5.5 and 65-125/7.5

[2] For version 32-200, 40-200, 50-160, 50-200

[3] Quantity=10 for 32-160, 40-160, 50-125, 65-125

Quantity=12 for 32-200, 40-200, 50-160, 50-200, 65-160, 65-200

[4] Only for 65-160/15 and 65-200

[5] FPM for H-HS-HW-HSW version

EPDM for E version, Q1AEGG, Q1U3EGG, U3CEGG, Q1Q1EGG

U3U3EGG not available for models 65-160/15 and 65-200

(3/3) Construction

Pump name 3LSF 32-200/5.5

Customer	Date 19-May-2020	Company
Contact	Item no.	Issued by
Phone	Project	Phone
E-mail	Project ID	E-mail

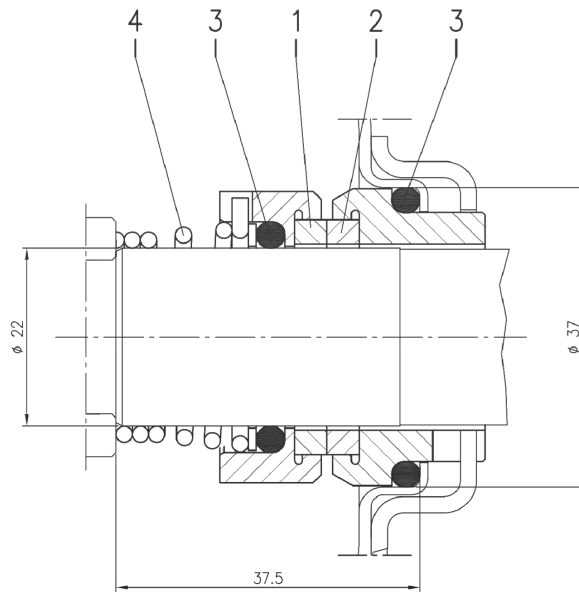

Version	Pump type	Material			
		1 Stationary seal ring	2 Rotary seal ring	3 Rubber	4 Frame + spring
L ø22	32-125/160/200 40-125/160/200 50-125/160/200 65-125 65-160/7.5-9.2-11	SiC	SiC	FPM	EN 1.4571 (AISI 316Ti)