

PART LIST MODEL: PD16S

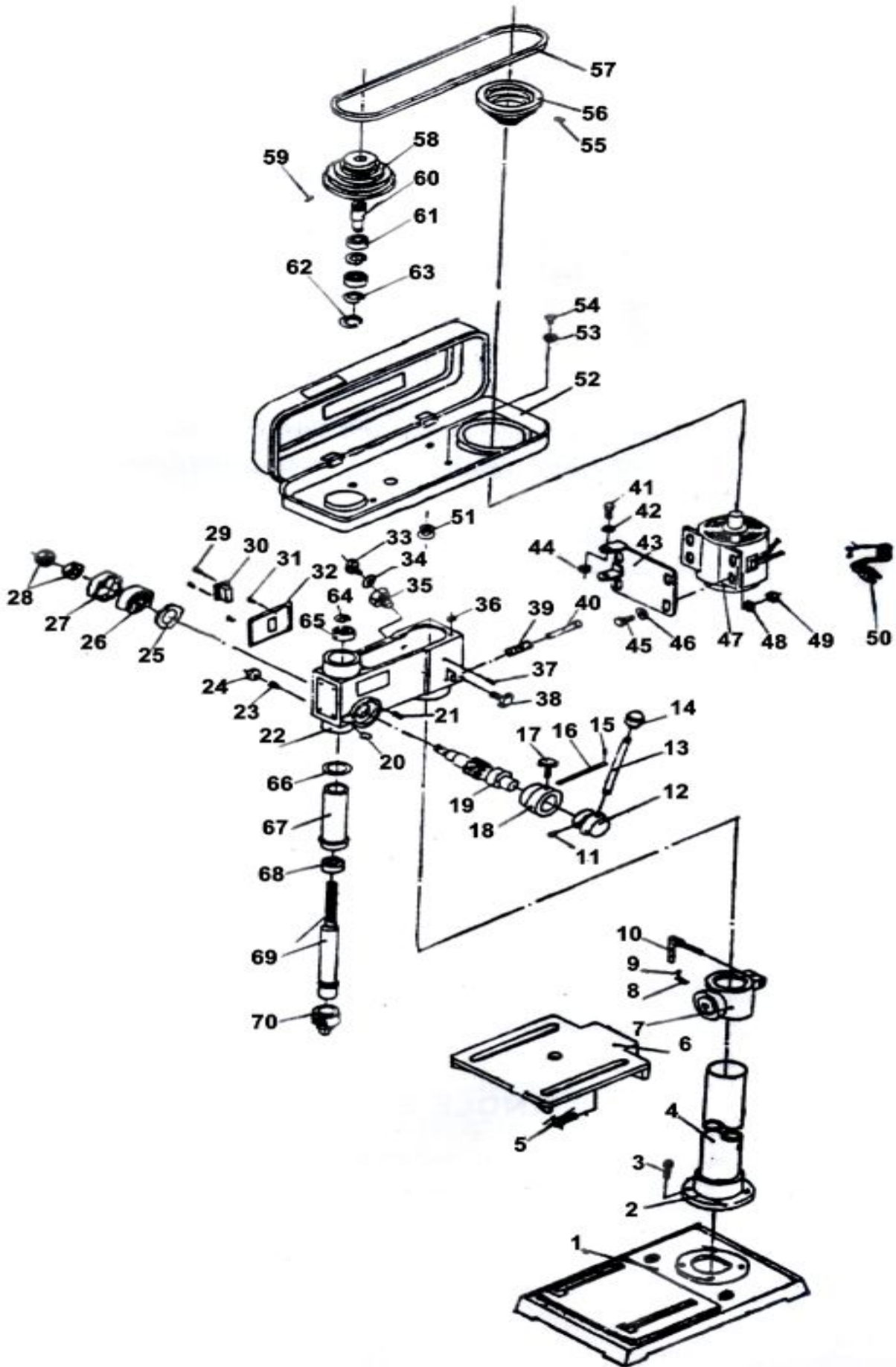

## PART LIST

Part No.	Description	size	Qty	Part No.	Description	size	Qty
1	Base		1	36	Rubber washer		4
2	Column Holder		1	37	Roll pin	Φ6X24	2
3	Hex.Hd.Bolt	M8X25	4	38	Lock screw		1
4	Column		1	39	Spring		1
5	Hex.Hd.Bolt	M12X25	1	40	Slide rod		1
6	Table		1	41	Hex hd.screw	M8X30	2
7	Table bracket		1	42	Flat washer		2
8	Scale		1	43	Motor plate		1
9	Rivet		1	44	Hex nut	M8	2
10	Column lock handle		1	45	Hex hd.srew	M8X25	4
11	Pin		1	46	Flat washer		4
12	Pinion assembly		1	47	MOTOR		1
13	Handle		3	48	Flat washer		4
14	Ball		3	49	Hex nut	M12	4
15	Rivet		1	50	Power cord		1
16	Scale		1	51	Cord insulator		1
17	Lock screw		1	52	Pulley cover		1
18	Depth indicator		1	53	Flat washer	Φ6	4
19	Feed shaft		1	54	Cheese hd.screw	M6X12	4
20	Pointer		1	55	Hex socket set screw	M6X10	1
21	Stop pin		1	56	Motor pulley		1
22	Head		1	57	V-belt		1
23	Hex.socket set screw	M8X18	1	58	Spindle pulley		1
24	Hex.nut	M8	1	59	Hex socket set screw	M6X10	1
25	Spring retainer		1	60	Spindle sleeve		1
26	Coil spring		1	61	Bearing		1
27	Spring cover		1	62	Retaining ring		2
28	Hex.Nut		2	63	Retaining ring		1
29	Cheese hd.srew		2	64	Retaining ring		1
30	Switch		1	65	Bearing		1
31	Cheese hd.srew		2	66	Rubber washer		1
32	Switch cover		1	67	Quill		1
33	Hex.socket set screw		2	68	Bearing		4
34	Wire insulator		2	69	Spindle		1
35	Wire cover		2	70	13mm chuck		1